

TEST REPORT



Concerning vehicles of categories O with regard to braking in accordance with ECE Regulation number 13.11 up to and including supplement 13.

Test report number : **RDW-13R-0040340**

0.1. Make : JMR

0.2. Type : SC (equipped with electric braking system)

0.3. Variety : 3 axle full trailer

0.4. Category of vehicle : O2

0.5. Name and address of the manufacturer : JMR trading BV
Weusdijk 1
7261 NG Ruurlo
the Netherlands

General : The braking system complies with the requirements laid down in section 5. of the above mentioned Regulation, **(except item 5.1.1.4. (EMC))**
See documentation: 201602 versie 3 (total of 5 pages)

Tests : The tests are carried out in accordance with:
Annex 4, 5, 6, 7, 8, 9, 10, 11, 12, 13, 14, 15, 17, 18, 19, 20, 21, 22 of the above mentioned Regulation.
See page 2 to 11.

Conclusion : The type of vehicle complies partly with the requirements and there are objections to granting the approval under the above-mentioned Regulation.
Conclusion only applies to vehicles with unladen mass not lower than 2625 kg
Item 5.1.1.4. EMC not proven, see remark on page 5.

Tests conducted on : 26/27/28 January 2016

By : B.v.d.Grift

Lelystad, 20 June 2016,
The test engineer,

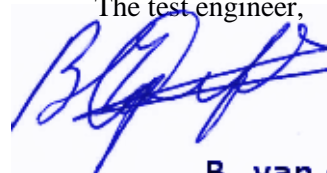

B. van de Grift



List of contents

- Reason for testing : see below
- Used test equipment : See below
- Meteorological conditions : page 3
- Identification of the tested vehicle : page 4
- Item 5 Specifications : page 5
- Annex 14 : page 6
- Weights and tests : page 7

List of attached diagrams

Subject	Diagram number
--	--

Reason for testing

New vehicle type.

Used test equipment

Item	Required accuracy	Registration number
Scale	10 kg	OPS07/08
Manometer	1 % of 1600 kPa	BVA18
Pressure sensor	2.5 % of 1000 kPa	DRU95
Speed measurement equipment	1 %	VYF78 GPS02
Wheel speed sensor	3 %	--
Amplifier		MVS87-93
Deceleration meter	0.3 m/s ²	
Pedal-force meter	2 daN	
Temperature meter	10 °C	TEM57
Tyre-pressure meter	20kPa	BVA17
Force measurement equipment	3 %	KRA09
Dynamometer	0.3 m/s ²	VTR10
Time measurement test equipment	0.2 %	STW09
Reaction-time measurement test equipment	0.02 sec	
Engine revolutions meter	2 %	
Length measurement equipment	class II	
Voltage / Ampere meter		UNV26

Remarks

...



Test report number: RDW-13R-0040340

Meteorological conditions

Date:	28-01-2015	Location of test track:	RDW Test Centre Lelystad
Barometric pressure	1028 mbar	Weather conditions	dry
Winddirection	W	Relative humidity	74 %
Temperature	7 °C	Wind speed	4 m/s



Test vehicle specifications												
Brake schedule:		Full trailer/Semi-trailer *										
Make and type		JMR SC			VIN			XL9SA800115225083				
Brake schedule number		201602 versie 2			Wheelbase			3880-650		mm		
Maximum allowed weight(mass):												
King pin		-- kg			--			kg				
Axle 1		1500 kg			1125			kg				
Axle 2		1000 kg			750			kg				
Axle 3		1000 kg			750			kg				
Totaal		3500 kg			2625			kg				
Axles:												
Make and type		Dexter			Code			Torflex 11 and 10				
Tyres:												
Axle number		Make and type			Tyre Size			Tyre Pressure				
Axle 1		Kenda Radial Kargo Pro			195/50R13C 104/101N			600 kPa				
Axle 2		Trailermax Radial			195/50R13C 104/101N			600 kPa				
Axle 3		Trailermax Radial			195/50R13C 104/101N			600 kPa				
Brakes:												
Make and type		Ax 1: Dexter 12x2			Ax 2+ 3: Dexter 10x2 ¼							
Brake specification:												
Axle number		1			2			3				
Brake cylinder(s)		--			--			--				
Disc/drum diameter		Ø305			Ø254			Ø254				
Drum identification		Dexter 8-388			Dexter 8-247			Dexter 8-247				
Lining make and type		DEX 2GG			DEX 1FF			DEX 1FF				
Lining width / length		50 / 238+305 mm			57 / 263+205mm			57 / 263+205				
Brake controller		SP 012-2 SN 2013490027			SP 012-2 SN 2013490010			SP 012-2 SN 2013490010				
Suspension:												
Type		Mechanical / Pneumatic / Hydraulic **										
Make		Dexter Torflex										
Dimensions		--										
Parking brake:												
Make		See documentation										
Type		See documentation										
On axle number		1, 2 and 3										
Brake lever length		See documentation										
Support legs		Not used during test										
ABS or EBS System: Not applicable												
Make and type		--										
Category ABS		--										
If applicable, report number for Annex XIV / Annex 19						Not applicable						
LSD settings: Not applicable												
LSD plate			Pass / Fail / Not applicable			Test connections			Pass / Fail / Not applicable			
P _m	bar	Suspension travel/suspension pressure		P _{out} LSD		Mass (kg)			LSD lever length			
Position		Front	Rear	Front	Rear	Front	Rear	Total	Front	Rear	mm	
Unladen		--	--	--	--	--	--	--	Rear	--	mm	
Laden		--	--	--	--	--	--	--				



Item 5 Specifications		
5.1.1.1	Braking system designed, constructed and fitted as to enable the vehicle in normal use, despite the vibration to which it may be subjected, to comply with the provisions of this Regulation.	PASS
5.1.1.2.	Braking system designed, constructed and fitted as to be able to resist the corroding and ageing phenomena to which it is exposed	PASS
5.1.1.3.	Brake lining shall not contain asbestos	PASS
5.1.1.4.	Does the braking system fulfil the requirement of Regulation 10: (a) 03 without a coupling for charging the RESS. (b) 04 with a coupling for charging the RESS	Not proven (1)
5.2.2.2.	Braking system O2 continuous or semi-continuous or inertia. Electrical braking system conforming Annex 14 shall be permitted	PASS Annex 14
5.2.2.4.1	The service braking shall act on all wheels of the trailer	PASS
5.2.2.4.2	The service braking shall distribute its action appropriately among the axles	PASS
5.2.2.5	Action of braking symmetrically to longitudinal median plane of the vehicle.	PASS
5.2.2.7.	Braking surfaces in constant connection with the wheels.	PASS
5.2.2.8.	wear of brakes shall be easily compensated	PASS
5.2.2.8.1.	wear adjustment shall be automatic. optional for O2	Not automatic
5.2.2.8.2.	Possible to easily check wear	PASS
5.2.2.8.2.2.	This information shall be made freely available e.g. vehicle handbook or electronic data record.	PASS
5.2.2.9.	Trailer is stopped automatically if coupling separates	PASS
5.2.2.10	Parking braking when trailer is separated from towing vehicle. Actuating by a person standing on the ground	PASS

-1) It is not proven if the braking system fulfils item 5.1.1.4. of the Regulation.



Annex 14		
1.1	The electrical control device regulating the voltage for the trailer shall be situated on the trailer.	PASS
1.2	The electrical energy required for the electrical braking system is supplied to the trailer by the towing vehicle.	PASS
1.3	Electrical braking systems shall be actuated by operating the service braking system of the towing vehicle.	PASS
1.4	The nominal voltage rating shall be 12 V.	PASS
1.5	The maximum current consumption shall not exceed 15 A.	PASS
1.6	The electrical connection of the electrical braking system to the towing vehicle shall be effected by means of a special plug and socket connection, the plug of which shall not be compatible with the sockets of the lighting equipment of the vehicle. The plug together with the cable shall be situated on the trailer.	PASS
2.1	If there is a battery on the trailer fed by the power supply unit of the towing vehicle, it shall be separated from its supply line during service braking of the trailer.	N/A
2.2	With trailers whose unladen mass is less than 75 per cent of their maximum mass, the braking force shall be automatically regulated as a function of the loading condition of the trailer.	Unladen mass > 75%
2.3	Electrical braking systems shall be such that even when the voltage in the connection lines is reduced to a value of 7 V, a braking effect of 20 per cent of the (sum of the) maximum stationary axle load(s) is maintained.	7 V gives 6.2 A Brake effect OK.
2.4	Control devices for regulating the braking force, which react to the inclination in the direction of travel shall, if the trailer has more than one axle and a vertically adjustable towing device, be attached to the chassis. In the case of single-axle trailers and trailers with close-coupled axles where the axle spread is less than 1 metre, these control devices shall be equipped with a mechanism indicating its horizontal position and shall be manually adjustable to allow the mechanism to be set in the horizontal plane in line with the direction of travel of the vehicle.	PASS
2.5	The relay for actuating the braking current in accordance with paragraph 5.2.1.19.2. of this Regulation, which is connected to the actuating line, shall be situated on the trailer.	PASS
2.6	A dummy socket shall be provided for the plug.	PASS
2.7	A tell-tale shall be provided at the control device, lighting up at any brake application and indicating the proper functioning of the trailer electrical braking system.	PASS
3.1	Electrical braking systems shall respond at a deceleration of the tractor/trailer combination of not more than 0.4 m/s ² .	PASS
3.2	The braking effect may commence with an initial braking force, which shall not be higher than 10 per cent of the (sum of the) maximum stationary axle load(s) nor higher than 13 per cent of the (sum of the) stationary axle load(s) of the unladen trailer.	PASS
3.3	The braking forces may also be increased in steps. At higher levels of the braking forces than those referred to in paragraph 3.2. of this annex these steps shall not be higher than 6 per cent of the (sum of the) maximum stationary axle load(s) nor higher than 8 per cent of the (sum of the) stationary axle load(s) of the unladen trailer.	N.A.

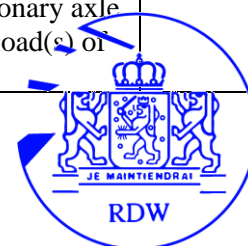

3.4	The prescribed braking force of the trailer of at least 50 per cent of the maximum total axle load shall be attained - with maximum mass - in the case of a mean fully developed deceleration of the tractor/trailer combination of not more than 5.9 m/s^2 with single-axle trailers and of not more than 5.6 m/s^2 with multi-axle trailers. Trailers with close-coupled axles where the axle spread is less than 1 m are also considered as single axle trailers within the meaning of this provision.	PASS
3.6	Automatic braking of the trailer shall be provided in accordance with the conditions of paragraph 5.2.2.9. of this Regulation. If this automatic braking action requires electrical energy, a trailer braking force of at least 25 per cent of the maximum total axle load shall be achieved for at least 15 minutes to satisfy the above-mentioned conditions.	PASS Not applicable



Test weight (mass) for type 0 brake tests					
Combination weight laden			Combination weight unladen		Tractor weight
Axle 1	1562	kg	1562	kg	1562 kg
Axle 2	1110	kg	1110	kg	1110 kg
Axle 3	1480	kg	1081	kg	
Axle 4	1050	kg	750	kg	
Axle 5	1050	kg	785	kg	
Total	6252	kg	5288	kg	2672 kg
Rolling resistance combination		0.01		Rolling resistance trailer	
				0.01	
Calculation factor for deceleration					
Laden		6252/3500 = 1.786			
Unladen		5288/2616 = 2.021			
Brake performance / Compatibility LADEN					
Deceleration [m/s ²] (combination is braked by brake pedal of tractor)	measured deceleration in jmr braking-system	Deceleration [m/s ²] (only trailer is braked with external computer)	Current intensity [A]	Deceleration calculated for trailer	Diagram number
1.01	0.12	0.60	0.55	0.11	24
2.08	0.20	1.15	1.20	0.21	25
2.87	0.30	1.65	2.35	0.31	26
4.04	0.40	2.13	4.30	0.39	27
4.97	0.50	2.90	8.90	0.54	28
5.80	0.60	3.04	10.0	0.57	29
Brake performance / Compatibility UNLADEN					
Deceleration [m/s ²] (combination is braked by brake pedal of tractor)	measured deceleration in jmr braking-system	Deceleration [m/s ²] (only trailer is braked with external computer)	Current intensity [I]	Deceleration calculated for trailer	Diagram number
--	--	0.55	0.7	0.12	34
--	--	1.31	1.5	0.28	35
--	--	1.88	2.6	0.40	36
--	--	2.71	4.5	0.58*	37
Parking brake					
Slope test					
Brake Force forwards		18	%	Brake force applied with spring (Knott system KFGL35)	
Brake Force rearwards		18	%	Knott spring partnumber 990029.01	
Control force		15	daN		
Diagram		--			
Brake force required		--	kN		
Test result parking brake : Pass/fail					

*Unladen condition only type 0 test performed. (The trailer unladen mass exceeds 75 percent of its maximum mass.)



LADEN:

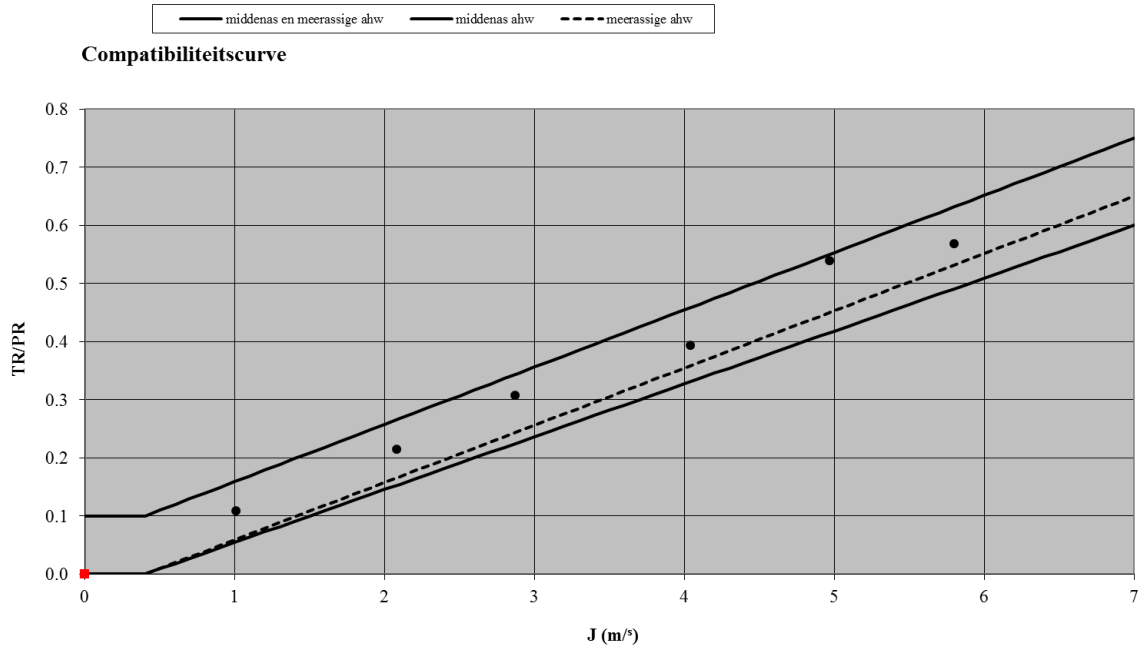

Deceleration tractor/trailer combination J m/s ²	T _R /P _R
1.01	0.11
2.08	0.21
2.87	0.31
4.04	0.39
4.97	0.54
5.80	0.57



Test report number: RDW-13R-0040340

UNLADEN

Not applicable.

Trailer inladen mass exceeds 75% of its maximum mass. Limits shall be applied only to laden condition.

Deceleration tractor/trailer combination J m/s²	T_R/P_R
--	--
--	--
--	--
--	--
--	--
--	--



Tests Type I and III on the vehicle

Test report number: RDW-13R-0040340

Type 0			Type I			Type 0 after I		
Speed	40.0	km/h	Speed	40	km/h	Speed	40.4	km/h
t 40-20	3.11	s	brake time	153	s	Comb decel	2.05	
current I	9.8	A	current I		A	current I	4.3	A
Deceleration	56	%	Force	325-1)	daN	Deceleration	37	%
Diagram	31		Distance	1700	m	Diagram	21	
			Diagram					
Tests continued:								
Type III			No	deceleration	control force	No	deceleration	control force
Speed		km/h	1			11		
Control force		daN	2			12		
Control pressure		bar	3			13		
Deceleration		m/s ²	4			14		
Time		s	5			15		
Diagram			6			16		
Type 0 after III			7			17		
Speed		km/h	8			18		
Control force		daN	9			19		
Control pressure		bar	10			20		
Deceleration		m/s ²	Remarks:					
Diagram								
Alternative procedures for Type I and III test for trailer brakes								
See test report number :			Not applicable					

$3500 \times 0.07 \times 9.81/10 = 240 \text{ daN}$
 + rolweerstand $0.015 \times 2672 \times 9.81/10 = 39 \text{ daN}$
 + uncertainty of the measurement equipment = 20 daN
 Total required towing force : 299 daN

After the type I test it was not possible to apply the brakes with the same control force. To avoid wheel lock the control force is decreased.



Beschrijving elektrisch remsysteem vlgs. tek. 201602 versie 3.

Het remsysteem is middels een **7 polige EBS steker (1)** elektrisch verbonden met het trekkende voertuig.

De **remregeling (2 en 3)** van het elektrisch remsysteem wordt geactiveerd door het remlichtsignaal van het trekkend voertuig. De remregelaar berekent de benodigde remvermogen aan de hand van 3 componenten.

1. G-sensor:
2. As last sensoren:
3. Programmeerbare parameters: oa dynamic wheel radius

Hierdoor wordt onder alle omstandigheden het juiste remvermogen geleverd.

Verder is de remregelaar uitgevoerd met twee alarmeringen. Deze alarmeringen worden doorgegeven aan de controle unit (9)

Alarmering remregelaar.

1. low battery:

De remregelaar controleert continu de voedingsspanning. Bij een lagere voedingsspanning als 11V zal de controle lamp “low bat” op de regelaar gaan branden.

2. Error:

Fout remkrachtregelaar. Niet van toepassing geen remkrachtregelaars nodig ivm “fixed weight”.

Voor in de cabine zijn twee controlelampjes rood (5) en groen (6) gemonteerd.

De rode controle lamp (5) is een storings indicatie lamp.

Deze geeft een storings weer bij een te lage accu spanning.

De combinatie dient zo snel mogelijk op een veilige manier tot stilstand te worden gebracht.

De bestuurder dient te controleren waarom er een te lage voedingsspanning is.

De aansturing van de rode controlelamp gebeurt rechtstreeks door de remregelaar. Zie verder alarmering remregelaar.

De groene controlelamp (6) is ter controle van de remwerking. Deze controle lamp is rechtstreeks verbonden met de kabel van de remspoelen. De lamp zal bij elke remming gaan branden als de remspoelen aangestuurd worden.



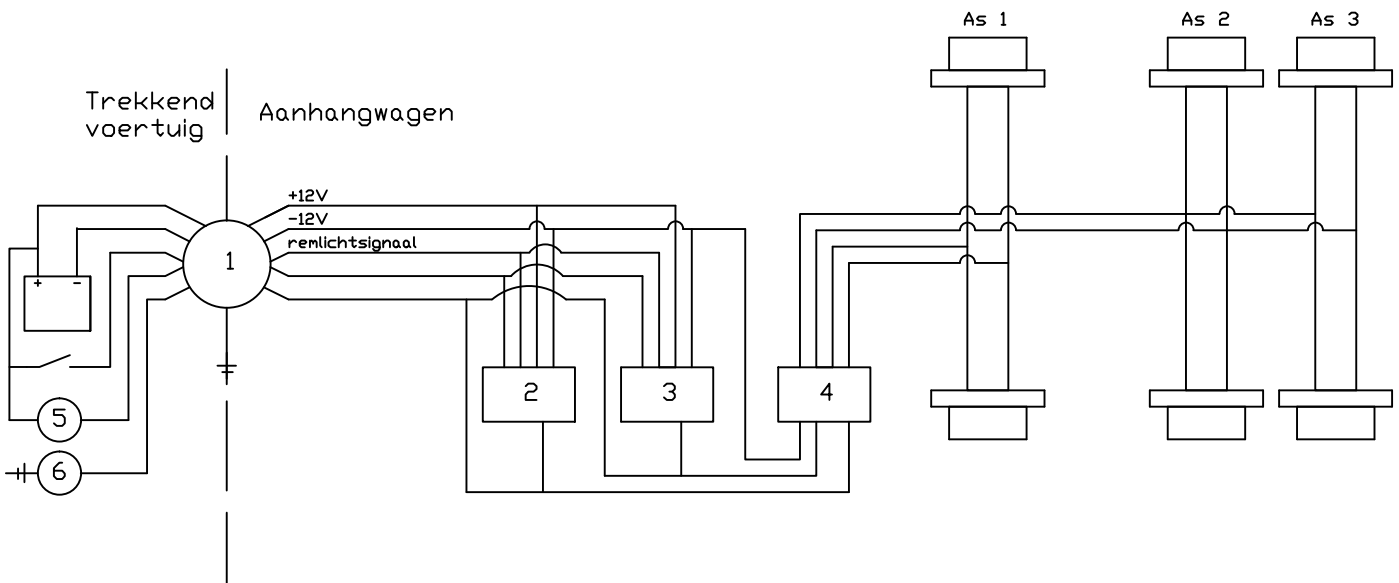

Aansluitdraden:

- * Remkrachtregelaar, zijn 0,75 mm².
- * Controlelamp remwerking en remlichtsignaal zijn 1 mm².
- * Overige zijn 2,5 mm².

1. Stekker, 7 polig.
2. Remregelaar as 1: merk: JMR TRading B.V.
Type: Jaco SP 012-2
3. Remregelaar as 2 en 3: merk: JMR TRading B.V.
Type: Jaco SP 012-2
4. Verdeeldoos remspoelen
5. Controlelamp storingen
6. Controle lamp remwerking

Dexter Axle	Brake drum Identification code	Wheel brakes	Brake Shoe
Axle 1	8-388 or 8-201	Type: 12x2	Dex 2GG
Axle 2 and 3	8-247	Type: 10x2 1/4	DEX 1FF



Dynamische bandenstraal: 267-302 ±5%

Fabrikant: JMR Trading B.V.
Weusdijk 1
7261 NG Ruurlo
Tel: +31(0)573 460936

Datum: 31-01-2016 get: G Smeets

Benaming:
Elektrische reminstallatie met
elektrische trommelremmen voor
autonome aanhangwagens met
vast gewicht.

1. Parkeerrem

2. Remmen

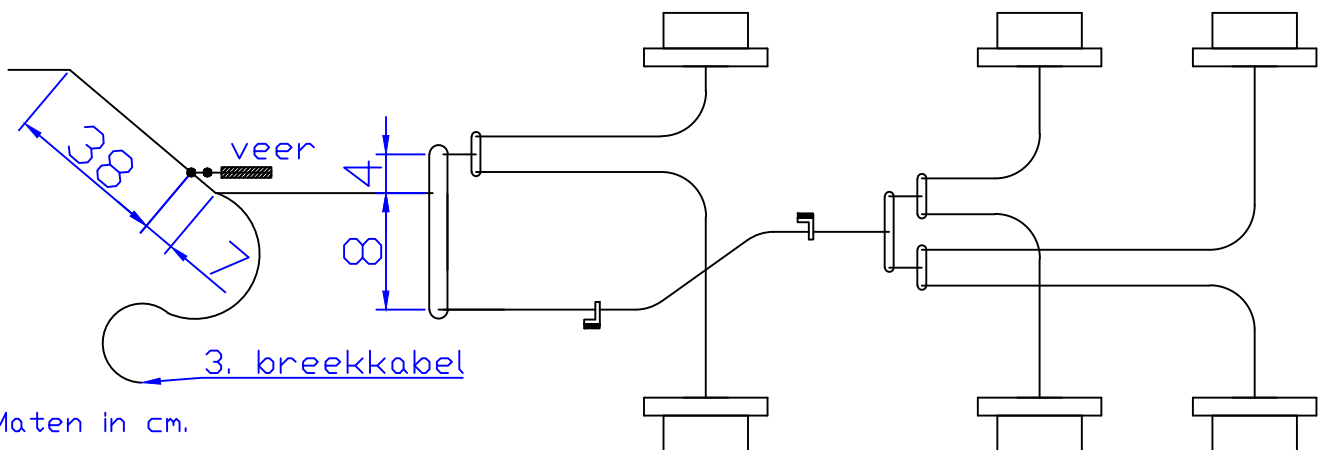

Maten in cm.

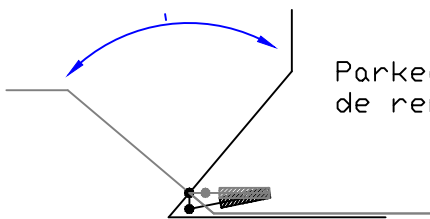

Parkeerrem met veer die de remkracht levert.

1. Parkeerrem / koppeling

Merk: Knott
Type: KFGL 35D met geblokkeerde
oploop inrichting

2. Remmen

Merk: Dexter
Type: Axle1: 12x2" with parking dvice
Axle2: 10x2¼ with parking dvice
Axle3: 10x2¼ with parking dvice

3. Breekkabel

Merk: Knott
Type: Breekkabel 203202.002



Voertuiggewichten		
	Min gewicht	Max gewicht
Totaal	2625 kg	3500 kg
As 1	1125 kg	1500 kg
As 2	750 kg	1000 kg
As 3	750 kg	1000 kg
koppeling		3500 kg

Fabrikant: JMR Trading B.V.
Weusdijk 1
7261 NG Ruurlo
Tel: +31(0)573 460936

Datum: 31-01-2016 get: G Smeets

Benaming:
Parkeerrem en losbreekrem voor
autonome aanhangwagens met
elektrische trommelremmen.

D35, #10 10" x 2¼" Electric Brake With Parking Feature

CSA approved at 3500#/13.3 SLR

2300 - 4000 LBS. CAPACITY

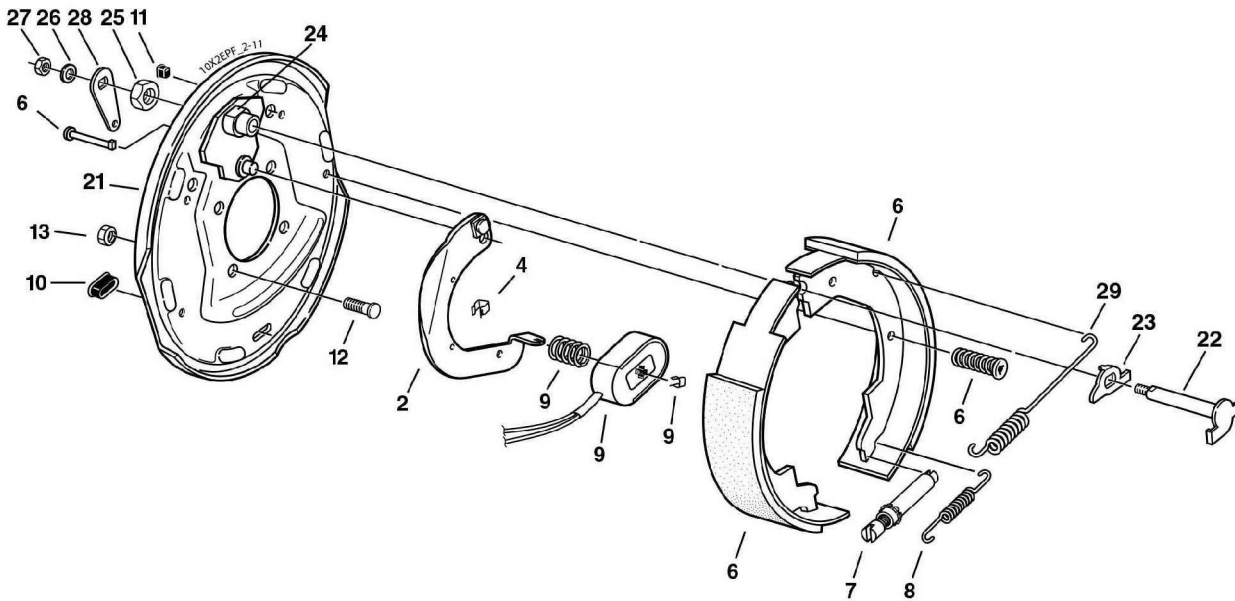

Electric Parking Brake

Item	Part No.	Qty/Brk	Description
0	K23-086-00	1	LH Complete Brake Assembly (shown)
0	K23-087-00	1	RH Complete Brake Assembly
2	047-019-05	1	LH Actuating Lever Arm
2	047-020-05	1	RH Actuating Lever Arm
4	027-005-00	3	Wire Clip
6	K71-047-00	1	Shoe & Lining Kit Contains: 1 #040-017-00 Primary Shoe & Lining 1 #040-021-00 Secondary Shoe & Lining 2 #049-002-00 Shoe Hold Down Pin #8 2 #046-077-00 Shoe Hold Down Spring & Cup
7	043-004-00	1	Adjuster Assembly
8	046-018-00	1	Adjusting Screw Spring
9	K71-104-00	1	Magnet Kit Contains: 1 #042-140-00 Magnet (green wire) 1 #027-009-00 Magnet Clip 1 #046-080-00 Magnet Spring
10	046-007-00	2	Adjuster Slot Plug
11	046-016-00	1	Wire Grommet
12	007-041-00	4	Brake Mounting Bolt - Press-in
*13	006-017-00	4	Brake Mounting Nut
21	036-019-07	1	LH Backing Plate Assembly (includes items #12, 22-28)
21	036-019-08	1	RH Backing Plate Assembly (includes items #12, 22-28)
22	039-025-00	1	LH Pivot Pin & Cam Sub-Assembly
22	039-026-00	1	LH Pivot Pin & Cam Sub-Assembly
23	039-048-00	1	LH Actuating Cam
23	039-049-00	1	RH Actuating Cam
24	038-047-00	1	Anchor Post & Bushing Assembly
25	006-047-00	1	Anchor Post Locknut
26	005-041-00	1	Washer
27	006-011-00	1	Pivot Pin Locknut
28	047-070-00	1	Actuating Lever
29	046-056-00	1	Retractor Spring

* Not included with complete brake assembly. Item sold separately.



Fabrikant: JMR Trading B.V.
Weusdijk 1
7261 NG Ruurlo
Tel: +31(0)573 460936

Datum: 31-01-2016 get: G Smeets

Benaming:
Constructie wielrem 10x2¼ voor
autonome aanhangwagens met
elektrische trommelremmen.

12" x 2" Electric Brake With Parking Feature



CSA approved at 6000#/14.2 SLR

5500 - 7000 LBS. CAPACITY

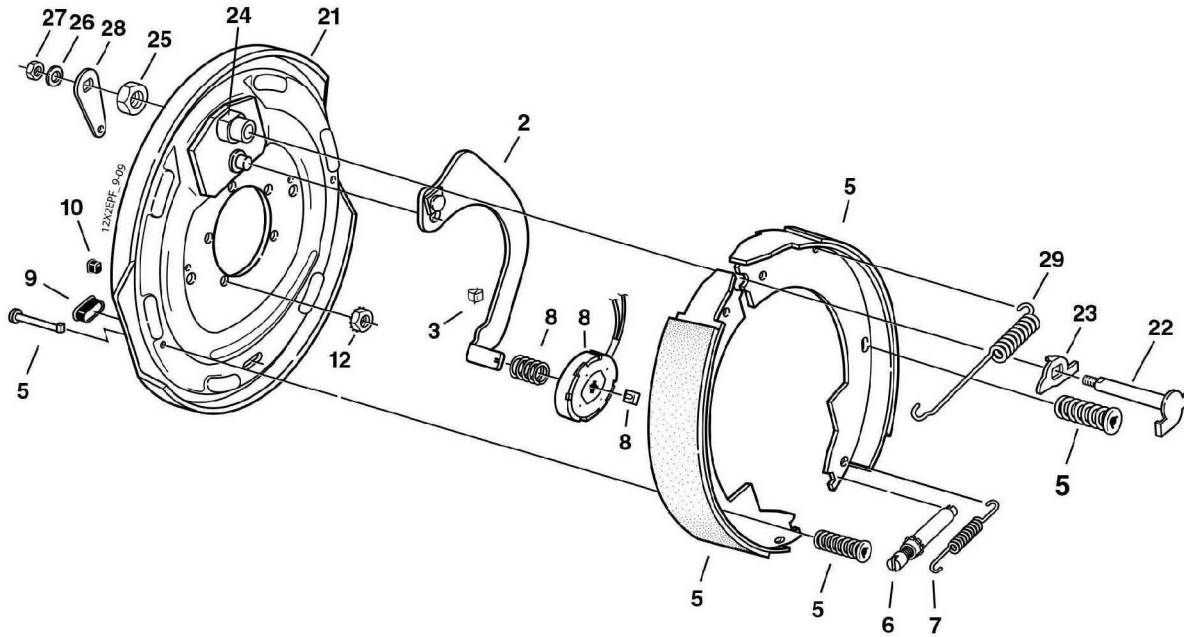

Electric Parking Brake 6000# (CSA 6000#)

Item	Part No.	Qty/Brk	Description
0	K23-328-00	1	LH Complete Brake Assembly
0	K23-329-00	1	RH Complete Brake Assembly
2	047-107-05	1	LH Actuating Lever Arm Assembly
2	047-108-05	1	RH Actuating Lever Arm Assembly
3	027-005-00	2	Wire Clip
5	K71-127-00	1	Shoe & Lining Kit Contains: 1 #040-215-00 Primary Shoe & Lining 1 #040-216-00 Secondary Shoe & Lining 2 #049-011-00 Shoe Hold Down Pin #2 2 #046-077-00 Shoe Hold Down Spring & Cup
6	043-004-00	1	Adjuster Assembly
7	046-018-00	1	Adjusting Screw Spring
8	K71-105-00	1	Magnet Kit Contains: 1 #042-144-00 Magnet (white wire) 1 #027-009-00 Magnet Clip 1 #046-080-00 Magnet Spring
9	046-007-00	2	Adjuster Slot Plug
10	046-016-00	1	Wire Grommet
*12	006-193-00	5	Nut Washer Assembly
20	036-089-08	1	LH Backing Plate Assembly Complete (includes #21-28)
20	036-089-09	1	RH Backing Plate Assembly Complete (includes #21-28)
21	036-089-06	1	LH Backing Plate Assembly
21	036-089-07	1	RH Backing Plate Assembly
22	039-025-00	1	LH Pivot Pin & Cam Sub-Assembly
22	039-026-00	1	RH Pivot Pin & Cam Sub-Assembly
23	039-048-00	1	LH Actuating Cam
23	039-049-00	1	RH Actuating Cam
24	038-068-00	1	Anchor Post & Bushing Sub-Assembly
25	006-047-00	1	Anchor Post Locknut
26	005-041-00	1	Washer
27	006-011-00	1	Pivot Pin Locknut
28	047-070-00	1	Parking Brake Lever
29	046-005-00	1	Retractor Spring



Fabrikant: JMR Trading B.V.
Weusdijk 1
7261 NG Ruurlo
Tel: +31(0)573 460936

Datum: 31-01-2016 get: G Smeets

Benaming:
Constructie wielrem 12x2" voor
autonome aanhangwagens met
elektrische trommelremmen.

**These brakes are rated to a
maximum capacity of 6000 lbs. / pair**